

611 EAST WALNUT
RAYMORE, MO 64083
ph 816-331-1917 fax 816-331-1971

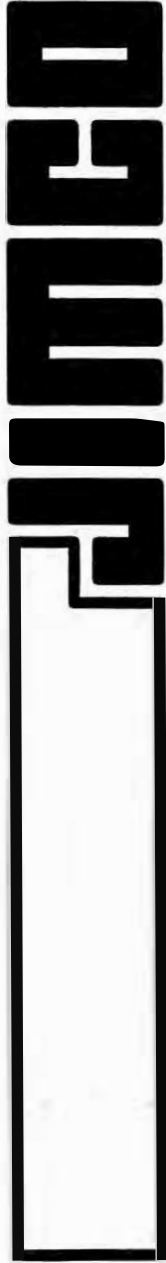

ELECTRICAL PARTS PICTURE GUIDE

RECTIFIER REGULATORS

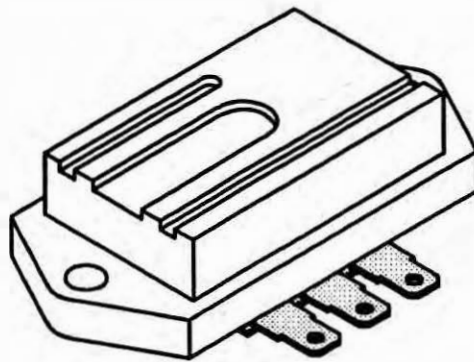
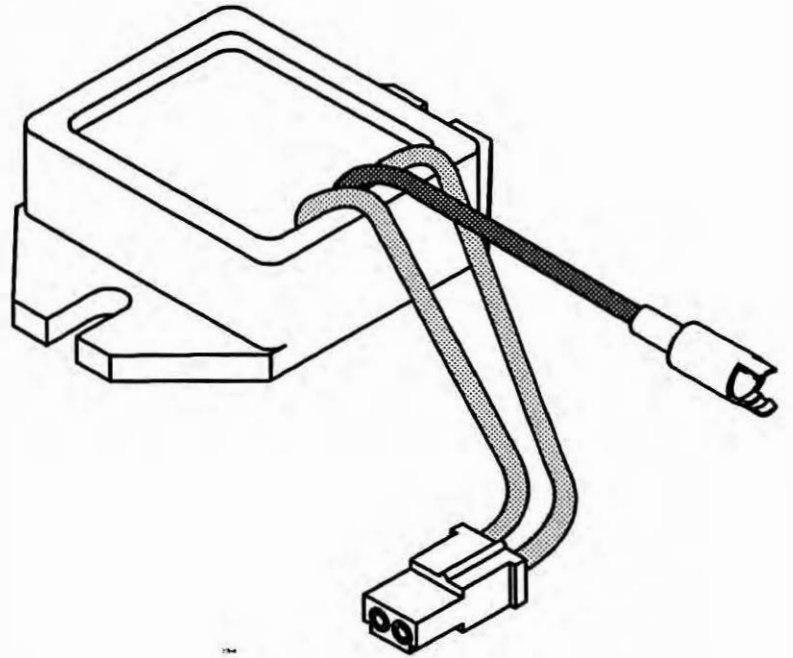

Who is JIMCO?

Since he began rebuilding voltage regulators over 25 years ago, James Grube has been filling a need in the automotive niche market. That's how JIMCO got its start.

Today JIMCO leads in the manufacture of specialized regulators and a growing line of solid state rectifier regulators and related components for small engines.

**JIMCO, INC.
611 EAST WALNUT
RAYMORE, MO 64083 USA**

**PHONE 816-331-1917
FAX 816-331-1971**

**Information in this publication was obtained from sources believed to be accurate.
JIMCO assumes no responsibility for possible errors.
Permission to reproduce any portion is denied.**

COPYRIGHT © 1997 JIMCO

JIMBO

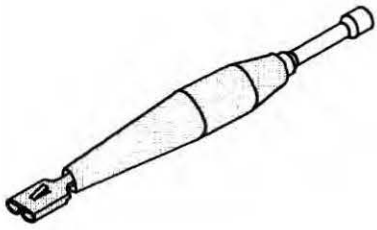

PART NUMBER

J1161

DIODE ASSEMBLY

Replacement for
TECUMSEH
611161

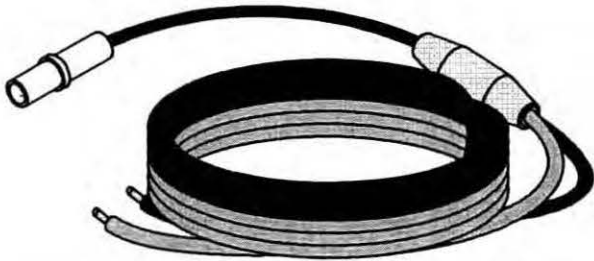

PART NUMBER

J2606

5 AMP TRI - CIRCUIT ALTERNATORS
6 amp diodes instead of OEM 3 amp

Replacement for
BRIGGS & STRATTON
392606

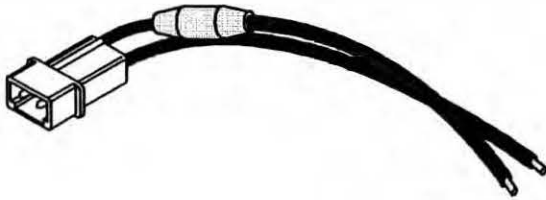

PART NUMBER

J3456

2 - 4 AMP DUAL CIRCUIT ALTERNATORS
6 amp diode instead of OEM 3 amp

Replacement for
BRIGGS & STRATTON
393456

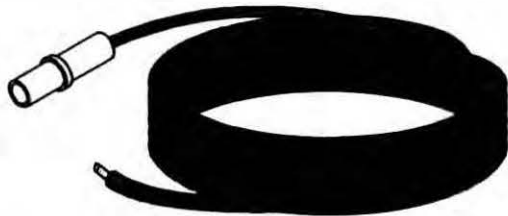

PART NUMBER

J3422

WIRE HARNESS

Replacement for
BRIGGS & STRATTON
393422

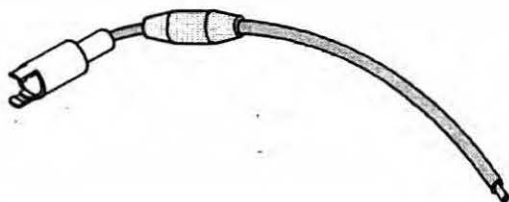

PART NUMBER

J3814

2 - 4 AMP CHARGING SYSTEMS
6 amp diode instead of OEM 3 amp

Replacement for
BRIGGS & STRATTON
393814

JIMBO

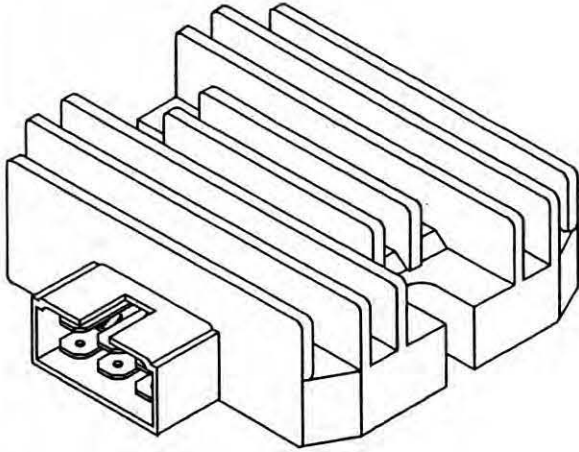

PART NUMBER
J4000

Replacement for
HONDA lawn tractor
316 00 890 951

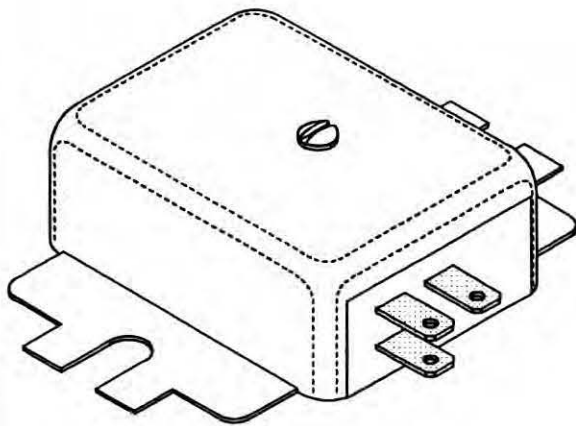
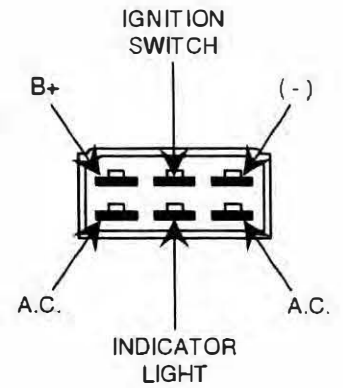

PART NUMBER
J4175
15 AMP CHARGING SYSTEMS
K SERIES 10 - 18 HP SINGLE CYLINDER

Replacement for

KOHLER
237335 (OLD NO.)

JOHN DEERE
AM 37200
AM 33845

JIMCO

PART NUMBER

J4200

10, 13, 14 & 16 AMP CHARGING SYSTEMS
8 - 20 HP ENGINES

Replacement for

BRIGGS & STRATTON

394890

393374

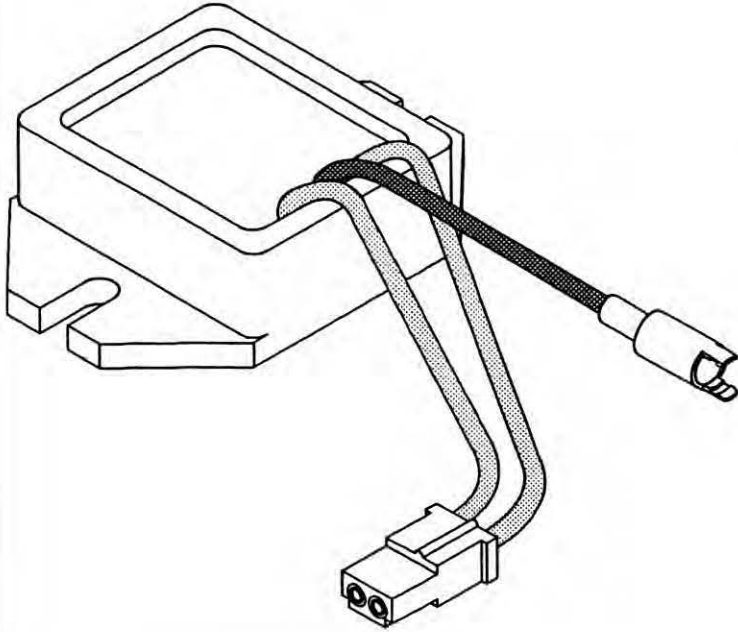

PART NUMBER

J4250

16 AMP DUAL OUTPUT CHARGING SYSTEMS
(WITH "NO CHARGE" INDICATOR LIGHT)
8 - 20 HP ENGINES

Replacement for

BRIGGS & STRATTON

493219

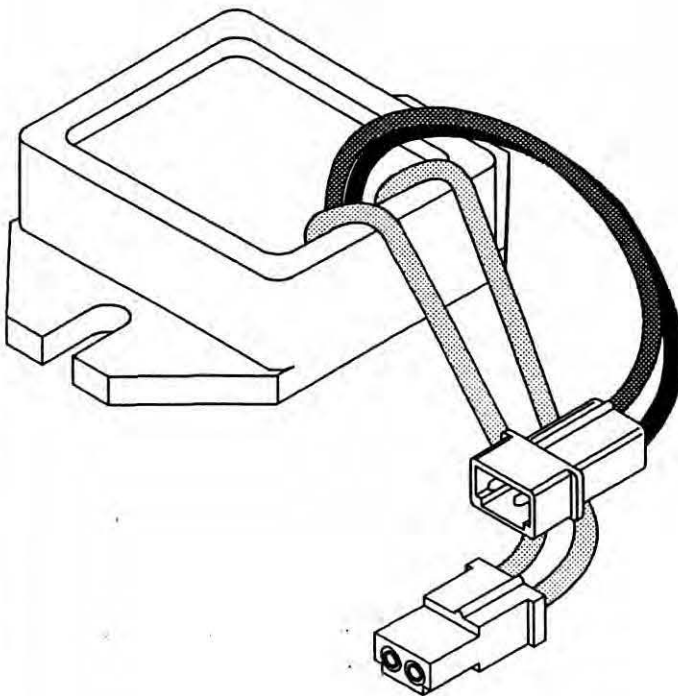

JIMCO

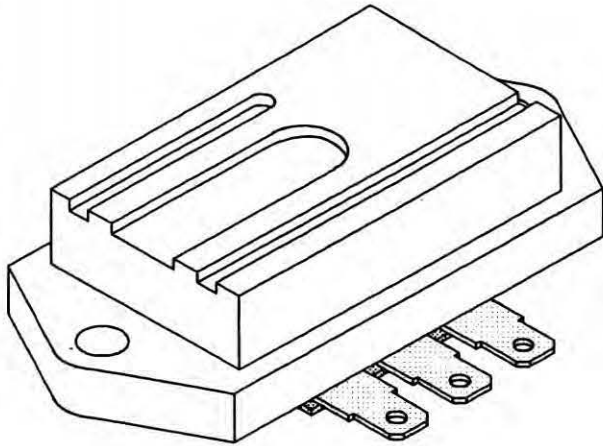

PART NUMBER

J4300

Replacement for

KOHLER

41-403-06

41-403-09

25-755-03

JOHN DEERE

AM 34738 (OLD NO.)

AM 106357 (NEW NO.)

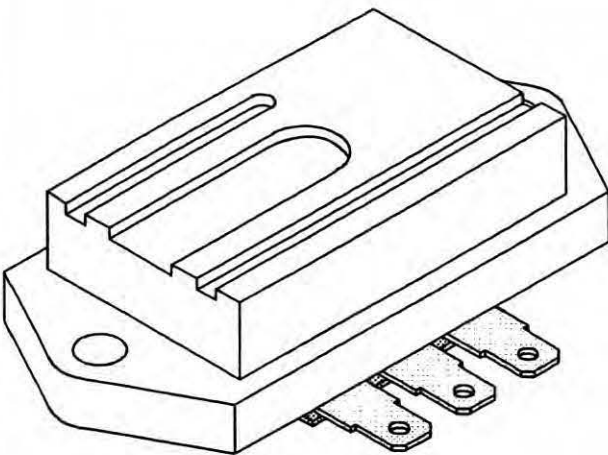

PART NUMBER

J4350

Replacement for

KOHLER

12-403-01

JOHN DEERE

M131287

Used on commercial walk behind mowers with Kohler engine with electric clutch, rope starter and no battery

JIMCO

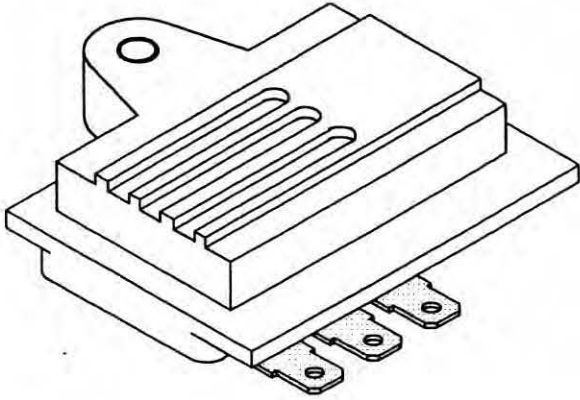

PART NUMBER

J4400

Used on JOHN DEERE
MODELS 318 - 420 LAWN TRACTORS
16 - 20 hp

Replacement for

ONAN

HE 191-1748

HE 191-2106

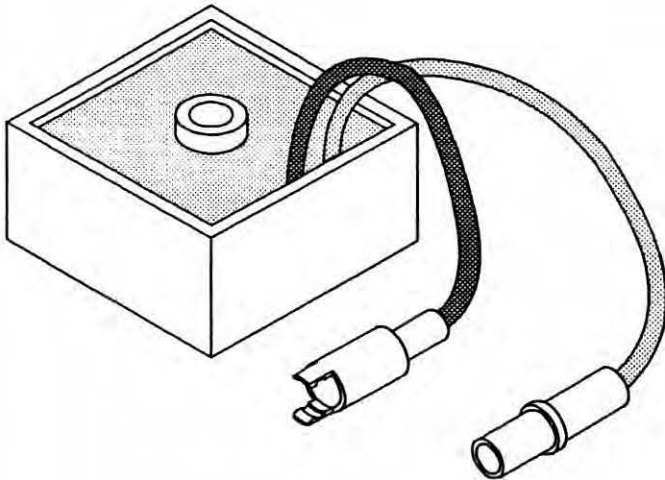

PART NUMBER

J4500

5 and 9 AMP CHARGING SYSTEMS

Replacement for

BRIGGS & STRATTON

491546

JIMCO

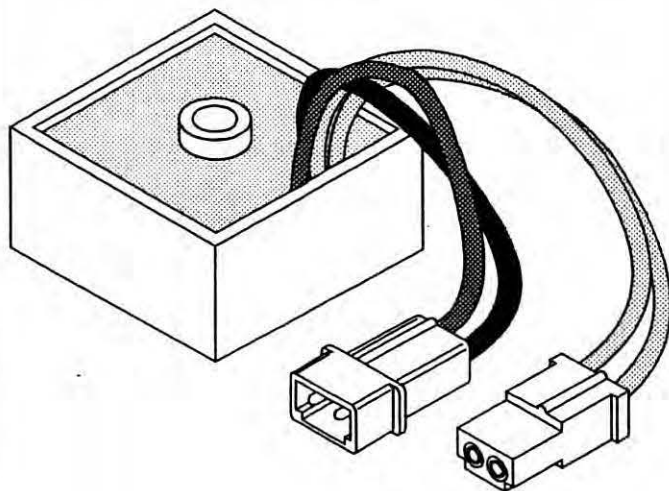

PART NUMBER

J4600

8 AMP "QUAD CIRCUIT CHARGING SYSTEMS

Replacement for

BRIGGS & STRATTON
3978809

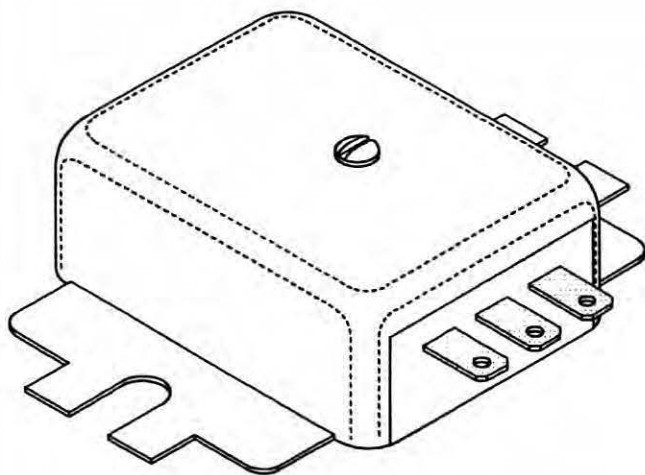

PART NUMBER

J4720

10 AMP CHARGING SYSTEMS
K SERIES 8 - 12 HP SINGLE CYLINDER

Replacement for

KOHLER
234279 (OLD NO.)
41 - 403 - 08 (NEW NO.)

JOHN DEERE
AM 102596

REPCO
FG - 4720

TECUMSEH
610749

JIMBO

REPLACED BY J5070

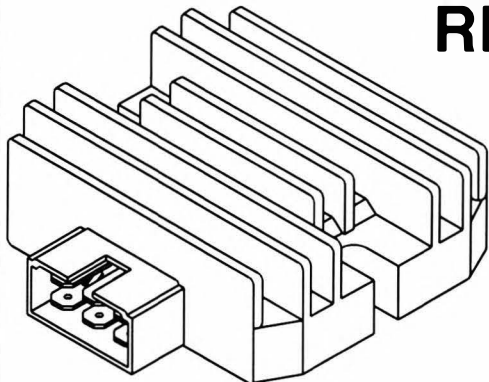

PART NUMBER
J4800

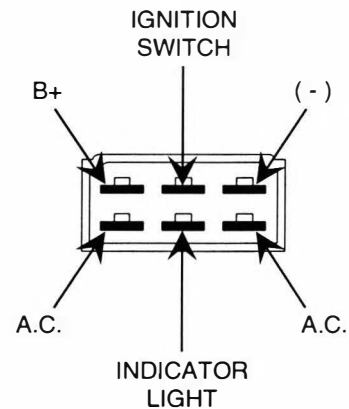

REPLACED BY J5070

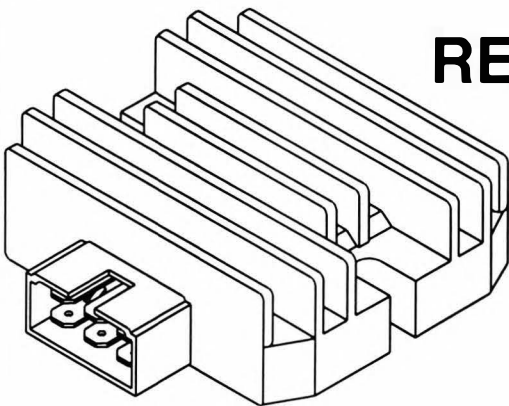

PART NUMBER
J4825

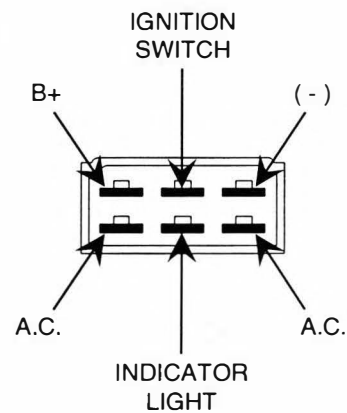

REPLACED BY J5070

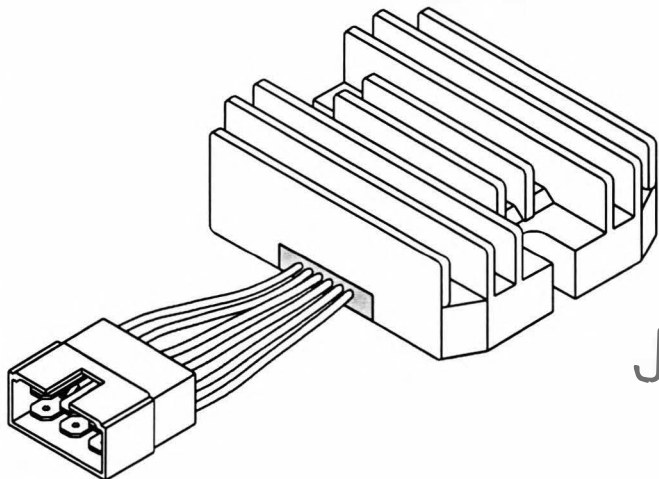

PART NUMBER
J5060

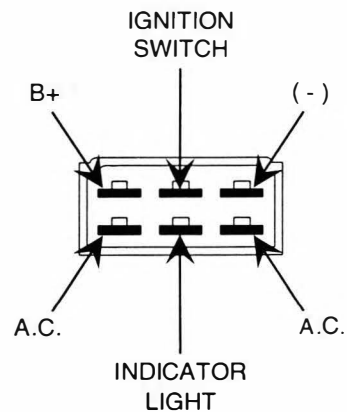

JIMBO

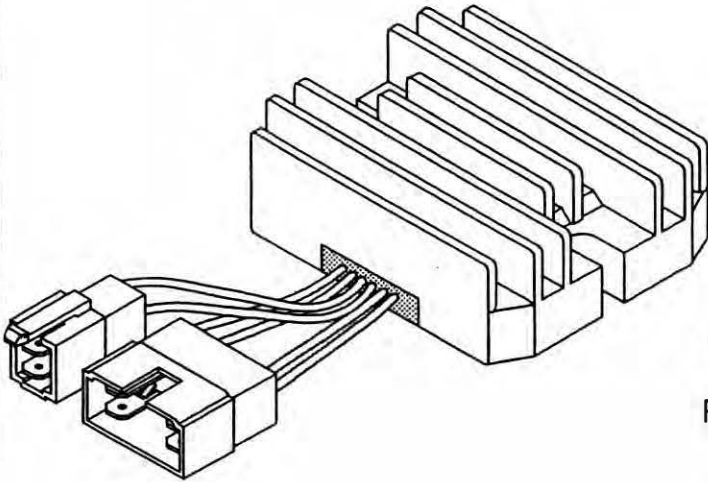

PART NUMBER
J4850

Replacement for

KAWASAKI
21066-2071

JOHN DEERE
AM109462

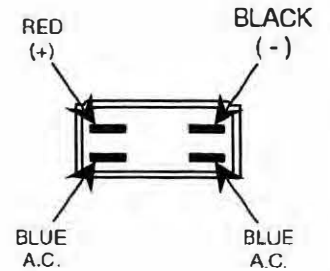
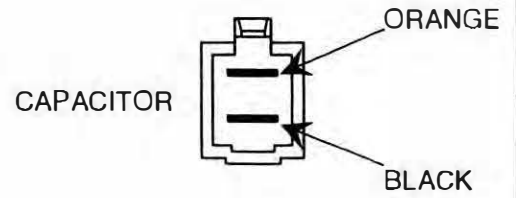

Used on commercial walk behind mowers with Kawasaki engine with electric clutch, rope start and no battery

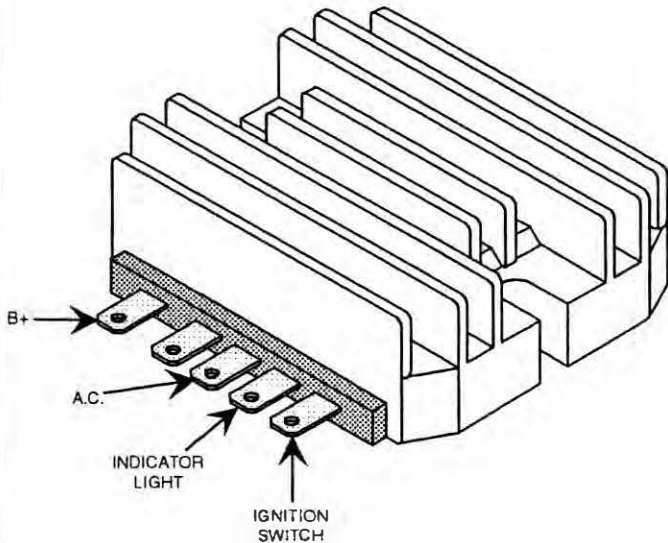

PART NUMBER
J4900

Replacement for

JOHN DEERE
AM101406

Used on garden tractor models 330, 322, 332
commercial mower model F915
compact tractors models 670, 770, 870, 970, 1070

JIMCO

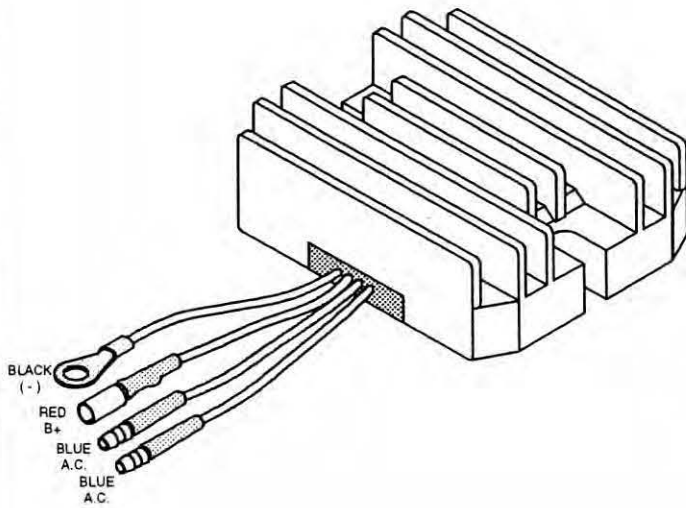

PART NUMBER

J5000

Used on early model **KUBOTA**
compact tractors with permanent magnet alternator
with**OUT** "no charge" indicator light
Replaces 66611-55250 and 67211-55230

RS1104

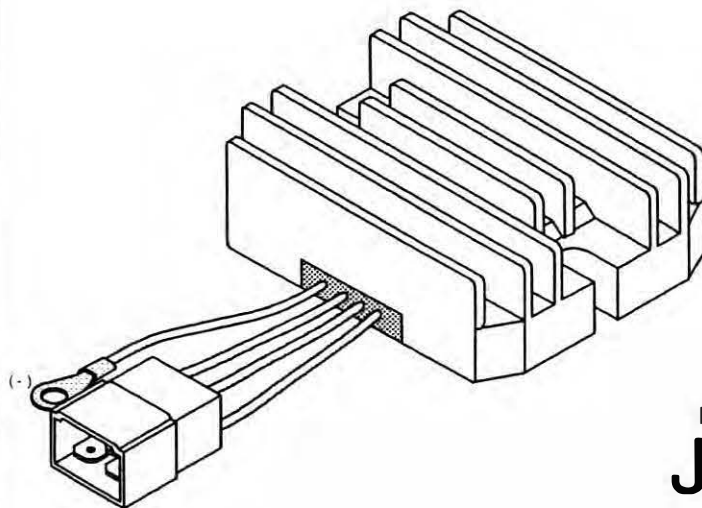

PART NUMBER

J5025

Replacement for

MASSEY FERGUSON

RS5107

as used on model 205-4 and other
compact tractors

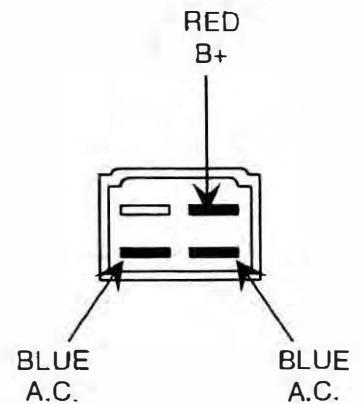

JIMCO

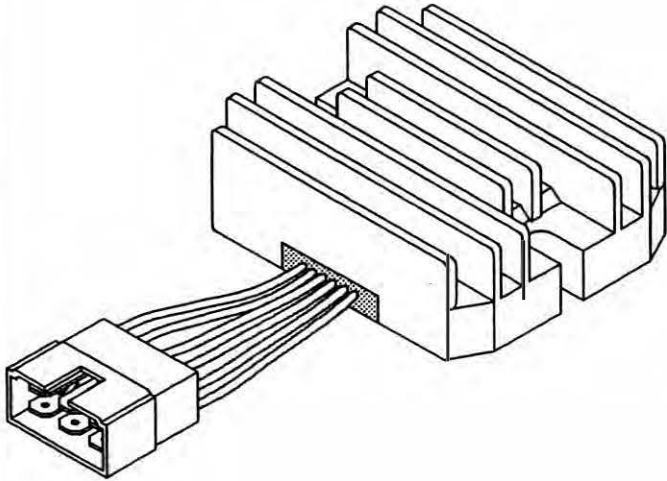

PART NUMBER
J5050

Replacement for

KUBOTA
RS5101, RS5155
15531-64601

GRASSHOPPER
185530

models 1822D, 718D, 721D, 721G

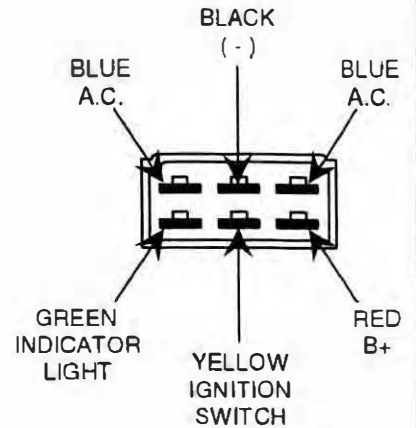

Used on lawn & garden, compact tractors and small industrial equipment with permanent magnet alternators with a "no charge" indicator light

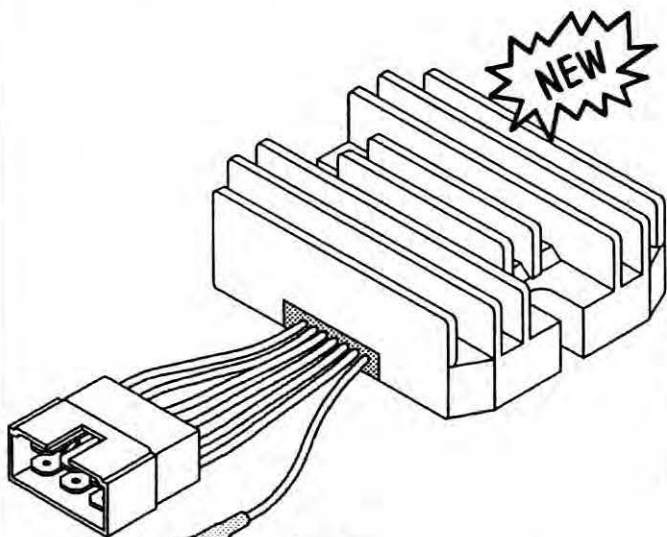

PART NUMBER
J5055

Replacement for

KOKUSAN-DENKI
RS5121

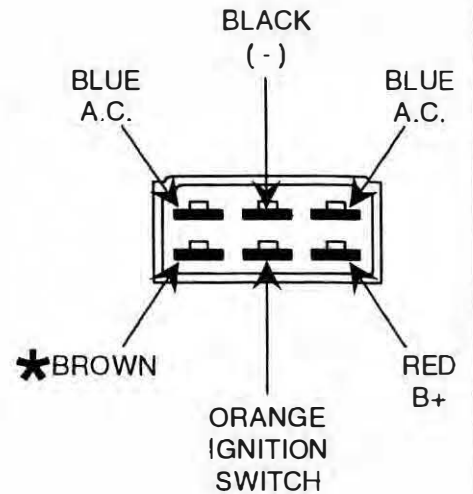

NOTE:

TERMINAL IS NOT AN INDICATOR LIGHT. IT IS A TERMINAL THAT BECOMES POSITIVE (+) WHEN ALTERNATOR IS CHARGING.

TERMINAL BECOMES NEGATIVE (-) THROUGH RECTIFIER (NOT GROUND) WHEN ALTERNATOR IS CHARGING.

Used on compact tractors and industrial equipment with permanent magnet alternators. Regulator has 7th. wire.

*YELLOW

JIMCO

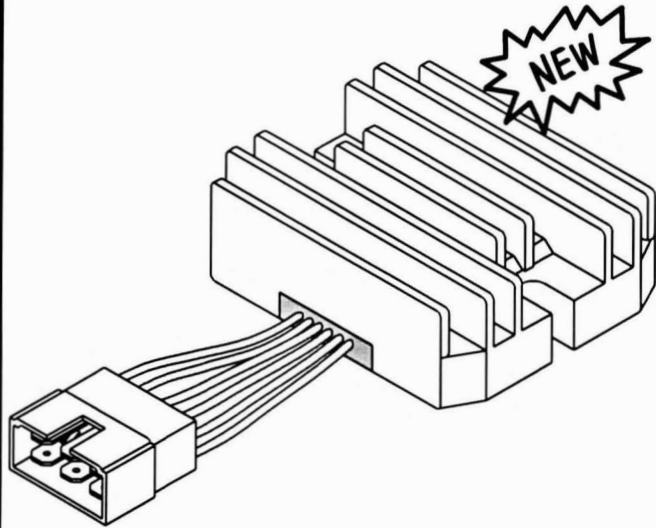

PART NUMBER
J5070

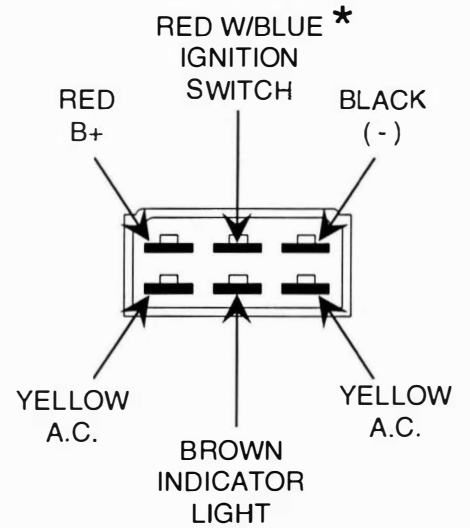

* J5070 COLOR IS ORANGE

Replacement for

JOHN DEERE

AM126304 M70121 M97348

models 130, 160, 165, 170, LX172, LX173, 175,
LX176, 178, 180, 185, 186, LX188, 240,
GT242, GT245, GT262, GT265, 277, 279,
GT285, 320, 325, 335, 345, 355, 425, 445, 455,
2653 and 2653A

F911, F510, F525, F710 and F725

ATM models 600, 622 and 626

4 X2, 6 X4 GATOR with 15 or 20 amp charging systems

2243 DIESEL GOLF EQUIPMENT

3375 SKID STEER

595 GARDEN TRACTOR

4100 UTILITY TRACTOR

KAWASAKI

21066-2056 21066-2070

engine models FB460, FC400, FC420 and FC540
13, 15 and 17 amp charging system on engines to 18 hp
20 and 22 horsepower water cooled V-twins

KOKUSAN-DENKI

RS5160

JIMCO

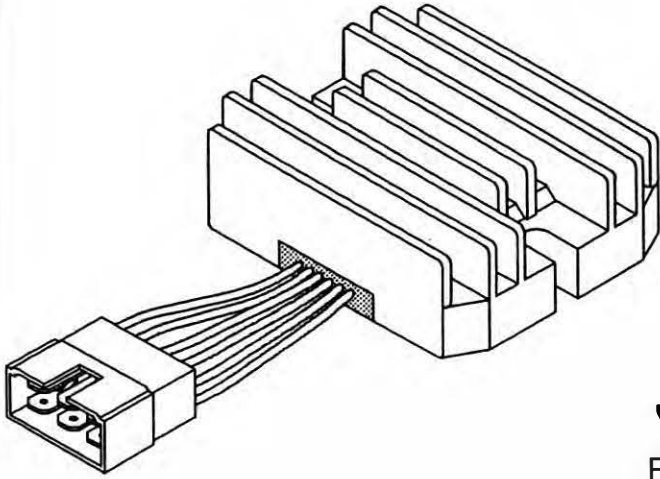

PART NUMBER
J5075

Replacement for

JOHN DEERE
M802471
models 650 and 750 compact tractors

RS5102, RS5104

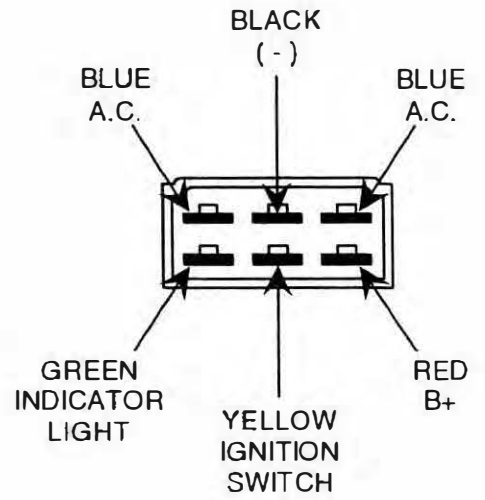

RAYMOR

PART NUMBER

J7060

Replacement
RECTIFIER - REGULATOR
for

**KOKUSAN-DENKI 12 VOLT
PERMANENT MAGNET ALTERNATORS
WITH INTEGRAL RECTIFIER - REGULATOR
SUCH AS: Lester 10930, 10931, PIC 299-140, 299-141
ISUZU 877-295-2712
8970048-970-0, ..-1, ..-2
897226-840-0, ..-3**

**MADE IN
RAYMORE, MO USA!**

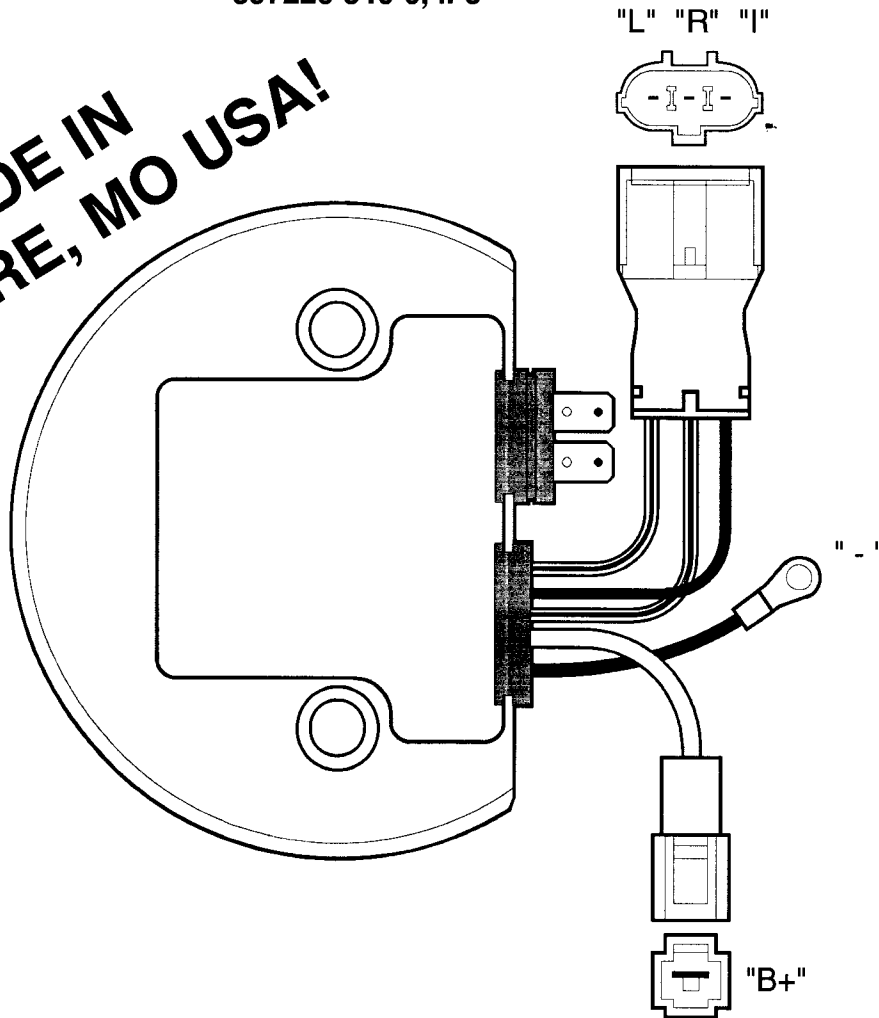

**OPERATED WITH AN ALTERNATOR
BEFORE POTTING AND AGAIN AFTER !**

REGS.DRW 1-13, R-0

JIMBO

HARNESS REPAIR CONNECTORS FOR RECTIFIER - REGULATORS

NOTE: Rectifier-regulator failure many times overloads and harms the harness connector.

C945

For **J5050** and **J5075** rectifier-regulators. Made with correctly color coded wires; POSITIVE and NEGATIVE wires are 14 ga. Includes butt connectors.



C150

For **J4175** rectifier-regulator. Made with color coded wires. Includes butt connectors.



C947

For **J4000**, **J4800** and **J4825** rectifier-regulators. Made with correctly color coded wires; POSITIVE and NEGATIVE wires are 14 ga. Includes butt connectors.

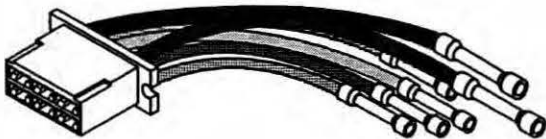

C325

For **J4720**, **J4300**, **J4350** and **J4400** rectifier-regulators. Made with color coded wires. Includes butt connectors.



C965

For **J5025** rectifier-regulator. Made with correctly color coded wires; POSITIVE and NEGATIVE wires are 14 ga. Includes butt connectors.

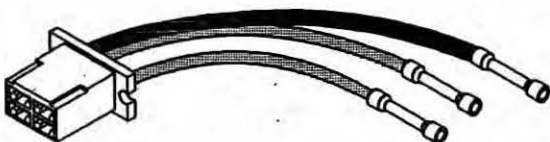

C490

For **J4900** rectifier-regulator. Made with color coded wires. Includes butt connectors.

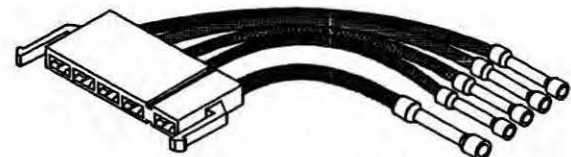

R960R

GOLF CART REGULATOR

Now **one** universal regulator to replace all
HITACHI "GOLF CART" STARTER/GENERATOR REGULATORS.

- Replaces **BOTH** mechanical and solid state versions.
- **Special circuitry prevents damage when operated in reverse (polarity reversal)!**
- 12 VOLT "A" CIRCUIT universal mounting.
- Terminal kit included for easy installation on the various configurations used by OEM.

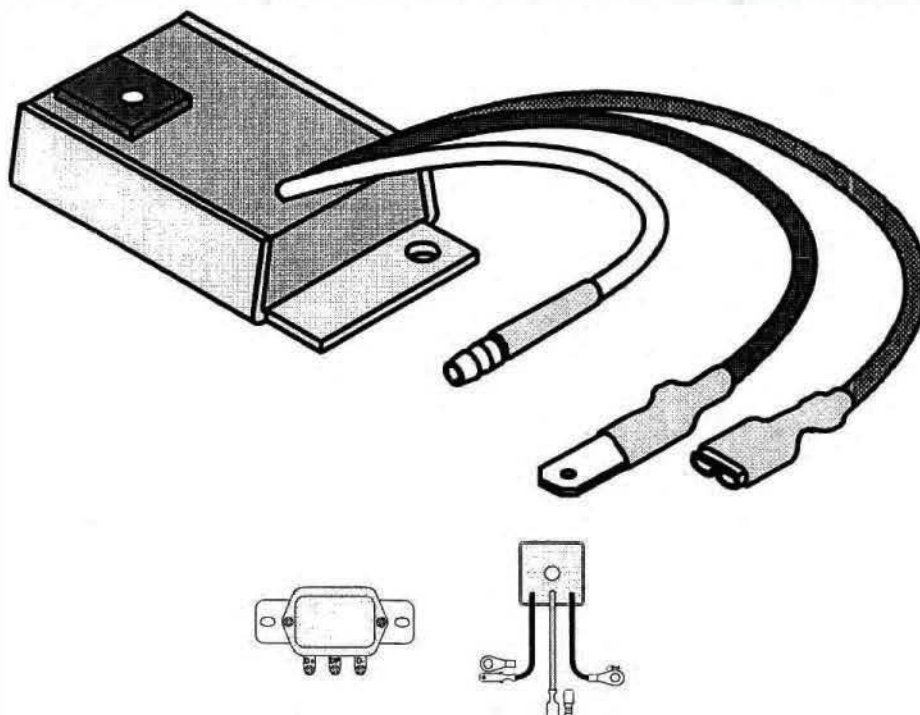

Replaces **BOTH** mechanical and solid state versions.

Just ask for the "reversible" one!

The **R960R** universal "A" circuit regulator can be ordered from many distributors nation-wide or from **JIMCO** at 800-821-7137, by fax 816-331-1971 or e-mail to JIMCOINC@AOL.COM